



1200W
Powerful
18.8 W/In.³
Small
1.3kg
Light

As a new generation of industrial-grade programmable power supply, AZ1200 series has digital design, which makes it have ultra-high programmable accuracy, Comprehensive parameter monitoring, multi-functional analog and digital interfaces, making your power system design more accurate and efficient.

The AZ1200 series is designed to comply with IEC/EN62368-1, IEC6061-1, EN55032 and relevant international standards

It empowers high-end industries and medical equipment continuously.

FEATURES:

- Programmable output Voltage (0% ~ 107.5%)
- Programmable output Current (0% ~ 107.5%)
- Analog and digital interface control
- I²C, Modbus, CAN bus communication protocol Selectable
- Constant current function
- Built-in OR-ing FETs
- Selectable 5V,2A or 12V,0.83A auxiliary output
- Intelligent GUI to set and monitoring parameter

MODEL	AZ1200-12	AZ1200-15	AZ1200-24	AZ1200-30	AZ1200-36	AZ1200-48	AZ1200-60
DC Voltage Rated	12V	15V	24V	30V	36V	48V	60V
Rated Current	83.3A	80A	50A	40A	33.33A	25A	20A
Rated Power	1000W	1200W					
Ripple & Noise(Max.)	150mVp-p	150mVp-p	150mVp-p	150mVp-p	150mVp-p	150mVp-p	240mVp-p
Efficiency(Typ.)	88.0%	89.5%	91.0%	92.0%	92.5%	93.5%	93.5%
<small>Note</small> 1.All parameters NOT specially mentioned are measured at 230VAC input, full load,25°C of ambient temperature. 2.De-rating may apply in low input voltage. Please check the de-rating curve for more details.							

+86 755-83045928

MODEL	AZ1200-12	AZ1200-15	AZ1200-24	AZ1200-30	AZ1200-36	AZ1200-48	AZ1200-60
Output Specifications							
DC Voltage Rated	V	12V	15V	24V	30V	36V	48V 60V
DC Current Rated	A	83.3A	80A	50A	40A	33.33A	25A 20A
Programming And Readback (I²C,RS485,CAN)							
Vout programming accuracy	--	0.05% of Vset +0.1% of rated output Voltage					
Iout programming accuracy	--	0.05% of Iset +0.1% of rated output current					
Vout programming resolution (Note.1)	--	3mV					
Iout programming resolution	--	3mA					
Vout readback accuracy	--	0.05% of actual +0.05% of rated output Voltage					
Iout readback accuracy (Note.1)	--	0.05% of actual +0.05% of rated output current					
Vout readback resolution	--	1mV					
Iout readback resolution	--	1mA					
Analog Programming And Monitoring (0~5V/0~5KΩ)							
Vout voltage programming	--	0~107.5%, 0~5V,Accuracy and linearity: ±0.5% of rated Vout.					
Iout voltage programming (Note.1)	--	0~107.5%, 0~5V ,Accuracy and linearity: ±1% of rated Iout.					
Vout resistor programming	--	0~107.5%, 0~5Kohm . Accuracy and nonlinearity: ±1% of rated Vout.					
Iout resistor programming	--	0~107.5%, 0~5Kohm .Accuracy and nonlinearity: ±1% of rated Iout.					
Output current monitor	--	0~3.3V user selectable. Accuracy: ±1%.					
Output voltage monitor	--	0~3.3V user selectable. Accuracy: ±1%.					
Constant Voltage Mode							
DC Voltage Rated	V	12	15	24	30	36	48 60
Programming Voltage Range	V	0~12.9	0~16.125	0~25.8	0~32.25	0~38.7	0~51.6 0~64.5
Ripple & Noise(P-P),Full load	mVp-p	150	150	150	150	150	150 240
Line Regulation (Note.2) ,Full load	--	±0.2%					
Load Regulation (Note.3)	--	±0.2%					
Remote sense compensation/wire	V	Max 2.5% of rate Vout					
Hold-up time,Full load, 100%~90%	--	16ms					
Constant Current Mode							
DC Current Rated	A	83.3A	80A	50A	40A	33.33A	25A 20A
Programming Current Range	A	0~89.5	0~86	0~53.75	0~43	0~37.47	0~26.87 0~21.5
Line regulation (Note.2)	--	±0.2%					
Load regulation	--	±0.2%					
Protective &Alarm Functions							
Input Over-voltage protection	--	AC input over 275VAC shutdown, auto recovery below 260VAC; Reset by AC input or by EN Singal or by communication port.					
Input under-voltage protection	--	AC input under 85VAC shutdown, auto recovery above 90VAC					
AC fail Alarm	--	AC input voltage below 50V for 50ms					
Output Over-voltage protection	--	Shut down, Reset by AC input or by EN Singal or by communication port.					
Over temperature Alarm(OTA)	°C	Ambient temperature over 53°C; auto-recovery under 48°C					
Over temperature protection(OTP)	°C	Heat-sink temperature over 95°C,shut down and auto-recovery under 75°C					
Over current protection(OCP)	--	Constant Current Limit					
Short circuit protection(SCP)	--	shut down and auto-recovery after the short-circuit removed					
Note: 1.Ripple & noise are measured at 20MHz of bandwidth by using 12" twisted pair-wire terminated with a 0.1uF & 47uF parallel capacitor 2.At 85~132Vac or 170~265VAC, constant load. 3.From No-Load to Full-Load, constant input voltage. Measured at the sensing point in Remote Sense.							
Function							
Local Remote control	--	By electrical Voltage: 5V/12V or dry contact					
DC-OK signal	--	Open Dragin singal, sink current ≤20mA, max drain voltage 40V					
Parallel operation	--	Possible, up to 16 units with single wire current balance connection.					
Series operation	--	Possible					
Auxiliary Power	--	Selectable +5V/2A or +12V/0.83A auxiliary output					
IOA	--	High speed I/O port (digital signal input/output)					
IOB	--	Low speed I/O port (analog singal input/output)					
Temperature measurement accuracy	°C	1					
Temperature display resolution	°C	0.1					
Input Specifications							
AC Input (Note.1)	Vac	90~264,Normal input 115VRMS/230VRMS					
DC Input	Vdc	127~370					
Input freq	HZ	47~63HZ,50/60HZ Typ 360~800,Contact factory for 400Hz application					
Input Current	--	230V/5.4A; 115V/15A					
Input Fuse	A	20,Each line fused 20A Slow acting					
Inrush Current	A	17.5A,115VAC; 35A,230VAC; 25°C cold start					

Power Factor	--	0.99,115VAC,full load, 0.98,230VAC,full load	
AC voltage measurement accuracy	--	$\leq \pm (Vin \cdot 1\% + 0.5V) / Vin$	
AC voltage measurement resolution	mV	10	
AC voltage measurement refresh rate	--	2.5 Times/Sec	
AC voltage measurement range	V	80~310VAC	113~450VDC
Static Power consumption	W	$\leq 8W, 25^{\circ}C$	
Equipment class	--	Class I	
Note: 1.For cases where conformance to various safety standards (UL, IEC, etc...) is required, to be described as 100-240Vac (50/60Hz).			
Environmental Conditions			
Operating temperature	$^{\circ}C$	-25~ +70 $^{\circ}C$. Contact factory for -40 $^{\circ}C$ application	
Storage temperature	$^{\circ}C$	-40~ +85 $^{\circ}C$	
Operating humidity	%	10~90 (Relative,Non-condensing)	
Storage humidity	%	5~95 (Relative,Non-condensing)	
Operating Altitude	m	-200~3000	
Non-Operating Altitude	m	-200~5000	
vibration	--	10~500Hz,2G 10min./1cycle,period for 60min.each along X,Y,Z axes Compliance to IEC 68-2-6,IEC 68-2-64	
Mechanical			
Dimensions (WxHxD)	mm	127*41*201.2 / (5.00*1.61*7.92 inch)	
Weight	KG	1.3KG/PCS; 15PCS/Carton, 22KG	
Cooling	--	Forced air cooling by internal fan	
Fan Speed	RPM	0~9000 \pm 10%, Intelligent fan control	
Fan Noise Level	dB	48.7,Fan Independent testing Note.1	
Others			
Warranty		3Years,	
MTBF	h	250000,MIL-HDBK-217F@25 $^{\circ}C$	

DE-Rating Curve

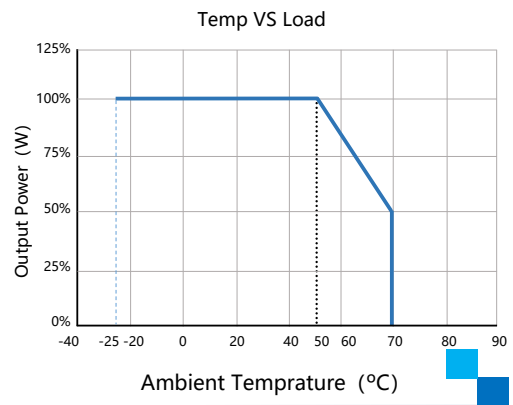
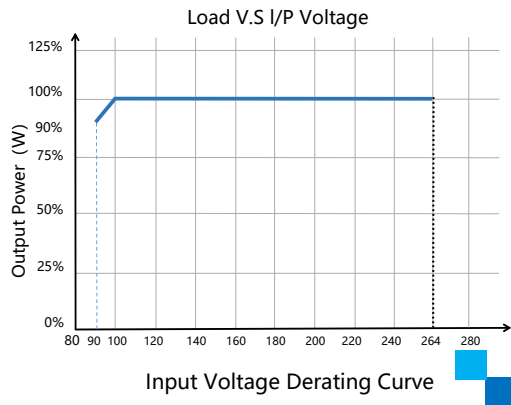

PIN Definition

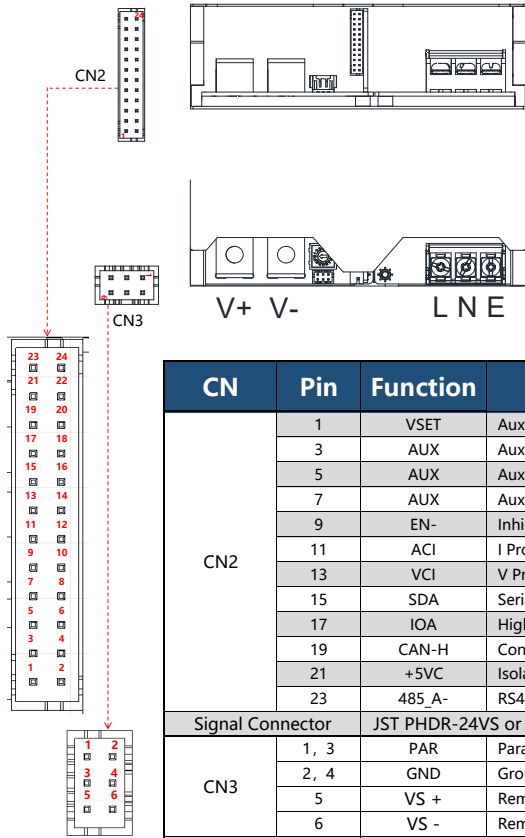

Pin	Function
L	AC Input L
N	AC Input N
E	AC Input FG
V+	DC Output (+)
V-	DC Output (-)

CN	Pin	Function	Description	Pin	Function	Description	
CN2	1	VSET	Aux output setting 5V/12V	2	POK	Power OK	
	3	AUX	Auxiliary output positive	4	GND	Ground	
	5	AUX	Auxiliary output positive	6	GND	Ground	
	7	AUX	Auxiliary output positive	8	EN+	Inhibit ON/OFF (+)	
	9	EN-	Inhibit ON/OFF (-)	10	GND	Ground	
	11	ACI	I Program	12	GND	Ground	
	13	VCI	V Program	14	GND	Ground	
	15	SDA	Serial Data Line	16	SCL	Serial Clock Line	
	17	IOA	High speed I/O port	18	IOB	Low speed I/O port	
	19	CAN-H	Controller Area Network-H	20	CAN-L	Controller Area Network-L	
	21	+5VC	Isolation 5V positive	22	GNDI	Isolation 5V Ground	
	23	485_A-	RS485 A+	24	485_B+	RS485 B-	
	Signal Connector JST PHDR-24VS or equivalent; JST SPHD-002T-P0.5 or equivalent						
	CN3	1, 3	PAR	Parallel operation current share			
2, 4		GND	Ground				
5		VS +	Remote sense(+)				
6		VS -	Remote sense(-)				
Signal Connector CJT A2006H-2x3P or equivalent; JST SPHD-002T-P0.5 or equivalent							

Remote ON/OFF

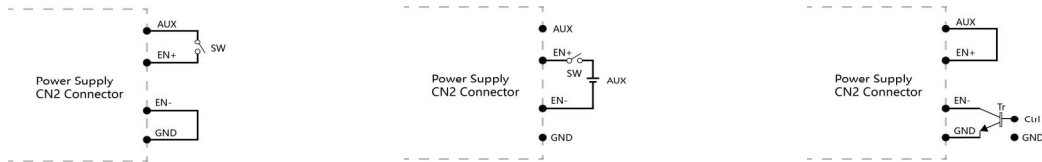

(a) Using internal 5V auxiliary source (Default Setting)

(b) Using external voltage source

(c) ON / OFF Control by NPN transistor

Note: GND shown in above diagram is referring to the GND of CN2, not the Grounding from main power(V-).

Output Voltage/Current Programming

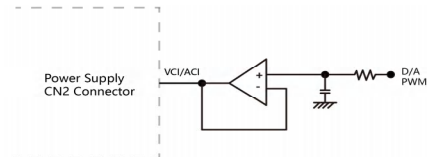
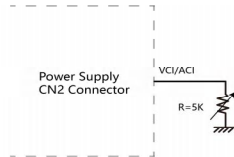
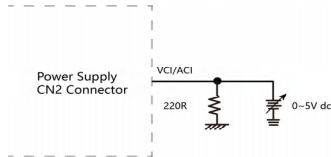
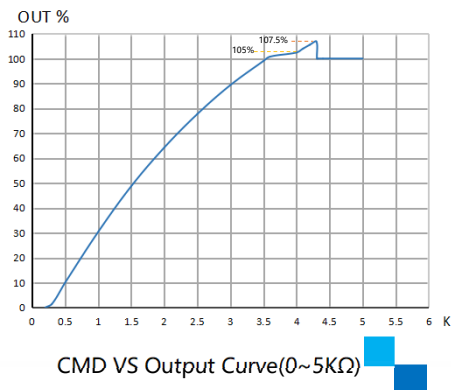
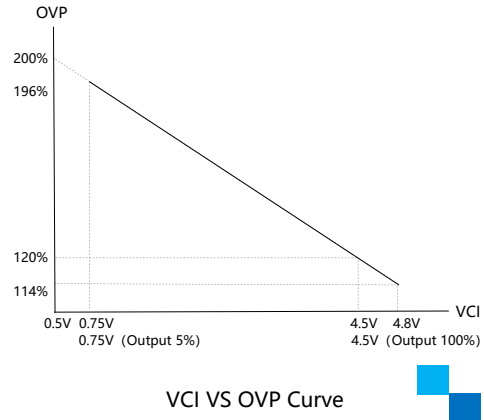
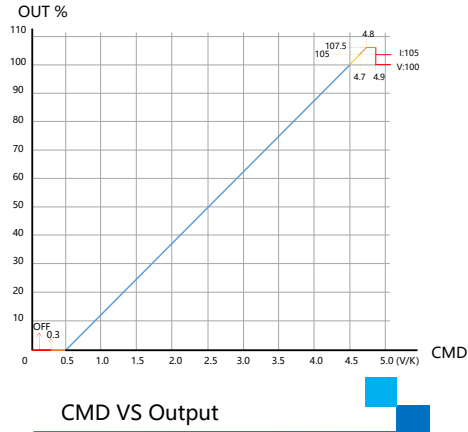

Power OK Signal & Auxiliary Power Setting

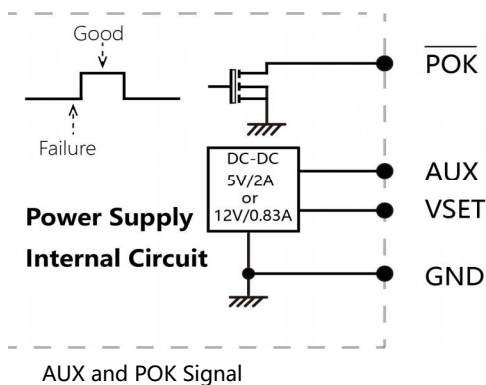

Do not exceed 5V/2A or 12V/0.83A

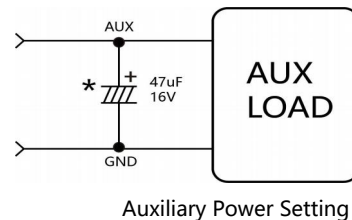

The grounding of "AUX" power and P.OK signals should be connected to "GND" port. If "V-" is connected as Grounding, make sure to short the GND and V- ports.

*Place an additional capacitor to have a better performance of auxiliary power operation.

Note:
GND shown in above diagram is referring to the GND of CN2, not the Grounding from main power(V-).

LED status indication

mode	Description	LED Signal	LED Slow=750ms; Fast=250ms
Local mode	Power Standby		Slow Blink (Green)
	Power OK		Solid (Green)
Remote mode	Power Standby		Slow Blink (Orange)
	Power OK		Solid (Orange)
Local/Remote mode	AC Failure		Alternating flicker (Red&Green)
	FAN Failure		
	OTA		
	AC Input Over /Under Voltage Protection		Fast Blink (Red)
	BUS Over Voltage Protection (OVP)		Intermittent Blink (Red)
	Over Load Protection (OLP)		Interlace Blink (Red)
	Over Temperature Protection (OTP)		Slow Blink (Red)
DC Output Over Voltage Protection (OVP)		Solid (Red)	

Mechanical Drawings

unit:mm

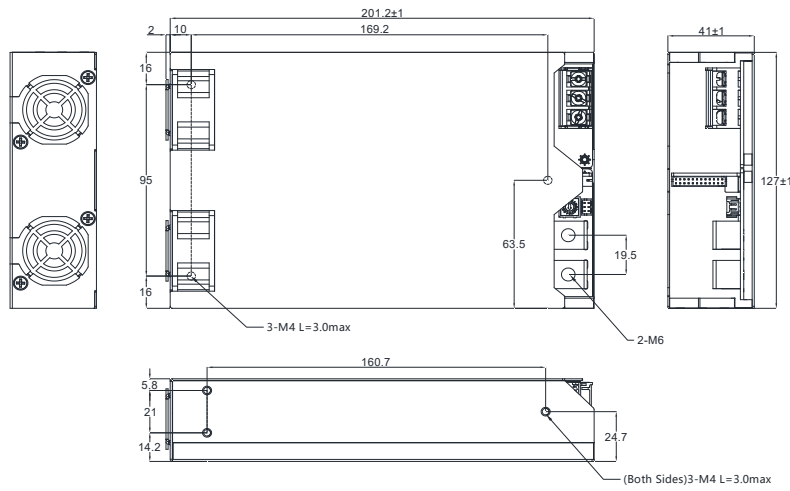

Notes:

- 1, Input terminal block type, M4 screw torque value of 16kgf·cm using wire gauge 18-10 (13mm centers)
- 2, Output terminal block, M6 screw in 2 positions, torque 3.5N·m (35kgf·cm)

Installation precautions

unit:mm

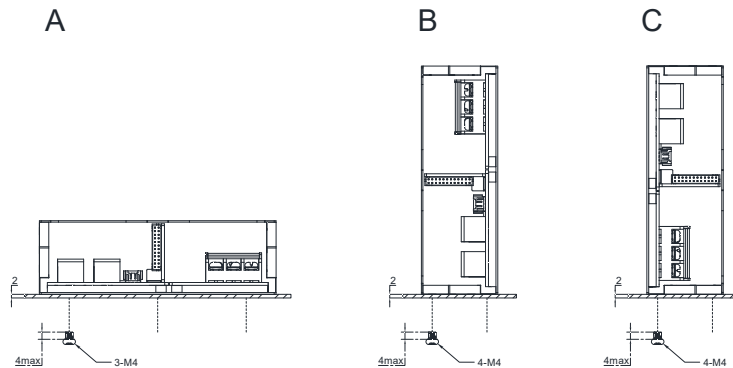

Notes:

- 1, Recommended standard mounting methods A, B, C
- 2, The Maximum allowable penetration of screw is 4mm. Incomplete threading should not be penetrated

Installation precautions

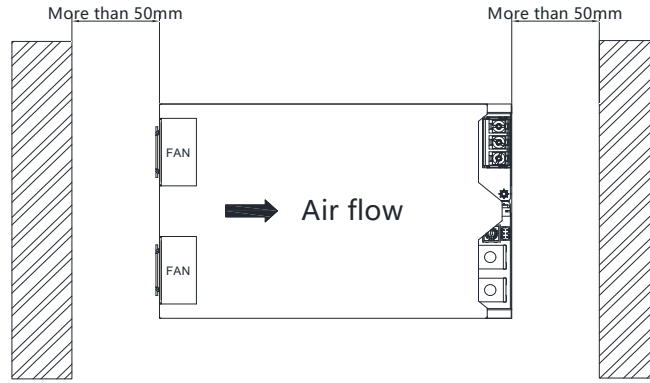

Notes:
There are ventilating holes on the front and back side panels, do not obstruct; allow 50mm at least for air flow.