



6000W
 Powerful
16.15 W/In.³
 Small
2.9kg
 Light

As a new generation of industrial-grade programmable conduction-cooling power supply, CW6000 series has digital design, which makes it high-density, high cost-effective, wide output-voltage range.conduction-cooled packaging, making your power system design more stabilize and efficient.

The CW6000 series is designed to comply with IEC/EN62368-1, EN55032 and relevant international standards

It empowers high-end industries and laser equipment continuously.

FEATURES:

- Programmable output Voltage (0% ~107.5%)
- Programmable output Current (0% ~107.5%)
- Fanless (Conduction cooling)
- Analog and I²C control
- Constant current function
- Modbus,485,CAN bus communication protocol (Optional)
- Selectable 5V,2A or 12V,0.83A auxiliary output
- Intelligent GUI to set and monitoring parameter

MODEL	CW6000-60 .HP	CW6000-100 .HP
DC Voltage Rated	60V	100V
Rated Current	100A	60A
Rated Power	6000W	
Ripple & Noise(Max.)	300mVp-p	500mVp-p
Efficiency(Typ.)	93.0%	93.0%

Note
 1.All parameters NOT specially mentioned are measured at 230VAC input, full load,25°C of ambient temperature.
 2.De-rating may apply in low input voltage. Please check the de-rating curve for more details.
 3.Model".HP"means high programmable accuracy edition(optional)



+86 755-83045928

MODEL		CW6000-60 .HP	CW6000-100 .HP
Output Specifications			
DC Voltage Rated	V	60V	100V
DC Current Rated	A	100A	60A
Programming And Readback : I²C, RS485;CAN (Optional)			
Vout programming accuracy	--	1% of Vset +0.5% of rated output Voltage	
Iout programming accuracy	--	1% of Iset +0.5% of rated output current	
Vout programming resolution (Note.1)	--	20mV	40mV
Iout programming resolution	--	40mA	20mA
Vout readback accuracy	--	1% of Vset +0.5% of rated output Voltage	
Iout readback accuracy (Note.1)	--	1% of Iset +0.5% of rated output current	
Vout readback resolution	--	1mV	
Iout readback resolution	--	1mA	
Analog Programming And Monitoring (0~5V/0~5KΩ)			
Vout voltage programming	--	0~107.5%, 0~5V, Accuracy and nonlinearity: ±1.5% of rated Vout.	
Iout voltage programming (Note.1)	--	0~107.5%, 0~5V ,Accuracy and nonlinearity: ±1.5% of rated Iout.	
Vout resistor programming	--	0~107.5%, 0~5Kohm . Accuracy and nonlinearity: ±1.5% of rated Vout.	
Iout resistor programming	--	0~107.5%, 0~5Kohm .Accuracy and nonlinearity: ±1.5% of rated Iout.	
Output current monitor	--	0~3.3V user selectable. Accuracy: ±1%.	
Output voltage monitor	--	0~3.3V user selectable. Accuracy: ±1%.	
Constant Voltage Mode			
DC Voltage Rated	V	60	100
Programming Voltage Range	V	0~64.5	0~107.5
Ripple & Noise(P-P),Full load	mVp-p	300mVp-p	500mVp-p
Line Regulation (Note.2) ,Full load	--	±1%	
Load Regulation (Note.3)	--	±1%	
Remote sense compensation / wire	V	Max 2.5% of rate Vout	
Hold-up time,Full load, 100%~90%	--	16ms	
Constant Current Mode			
DC Current Rated	A	60	100
Programming Current Range	A	0~64.5	0~107.5
Line regulation (Note.2)	--	±1%	
Load regulation	--	±1%	
Protective &Alarm Functions			
Input Over-voltage protection	--	AC input over 300VAC shutdown, auto recovery below 260VAC; Reset by AC input or by EN Singal or by communication port.	
Input under-voltage protection	--	AC input under85VAC shutdown, auto recovery above 90VAC	
AC fail Alarm	--	AC input voltage below 50V for 50ms	
Output Over-voltage protection	--	Shut down, Reset by AC input or by EN Singal or by communication port.	
Over temperature Alarm(OTA)	°C	Ambient temperature over 53°C; auto-recovery under 48°C	
Over temperature protection(OTP)	°C	Heat-sink temperature over 95°C,shut down and auto-recovery under 75°C	
Over current protection(OCP)	--	Constant Current Limit	
Short circuit protection(SCP)	--	shut down and auto-recovery after the short-circuit removed	
Note: 1.Ripple & noise are measured at 20MHz of bandwidth by using 12" twisted pair-wire terminated with a 0.1uF & 47uF parallel capacitor 2.At 85~132Vac or 170~265VAC, constant load. 3.From No-Load to Full-Load, constant input voltage. Measured at the sensing point in Remote Sense.			
Function			
Local Remote control	--	By electrical Voltage: 5V/12V or dry contact	
DC-OK signal	--	Open Dragin singal, sink current ≤20mA, max drain voltage 40V	
Parallel operation	--	Possible, up to 16 units with single wire current balance connection.	
Series operation	--	Possible	
Auxiliary Power	--	Selectable +5V/2A or +12V/0.83A auxiliary output	
IOA	--	High speed I/O port (digital signal input/output)	
IOB	--	Low speed I/O port (analog singal input/output)	
Temperature measurement accuracy	°C	1	
Temperature display resolution	°C	0.1	
Note: 1.The Constant Current programming, readback and monitoring accuracy do not include the warm-up and Load regulation thermal drift.			
Input Specifications			
AC Input (Note.1)	Vac	90~275,Normal input 230VRMS	
DC Input	Vdc	127~389	
Input freq	HZ	47~63HZ,50/60HZ Typ	
Input Current	--	230V/41A	
Input Fuse	A	50A ,Slow acting	
Inrush Current	A	60A,230VAC; 25°C	
Note 1.Please check the de-rating curve for more details.			

Power Factor	--	0.98,230VAC,full load
AC voltage measurement accuracy	--	$\leq \pm (V_{in} \cdot 1\% + 0.5V) / V_{in}$
AC voltage measurement resolution	mV	10
AC voltage measurement refresh rate	--	2.5 Times/Sec
AC voltage measurement range	V	80~310VAC 113~450VDC
Static Power consumption	W	$\leq 8W, 25^{\circ}C$
Equipment class	--	Class I

Note:

1.For cases where conformance to various safety standards (UL, IEC, etc...) is required, to be described as 100-240Vac (50/60Hz).

Environmental Conditions

Operating temperature	$^{\circ}C$	-25~ +50 $^{\circ}C$. Contact factory for -40 $^{\circ}C$ application
Storage temperature	$^{\circ}C$	-40~ +70 $^{\circ}C$
Operating humidity	%	10~90 (Relative,Non-condensing)
Storage humidity	%	5~90 (Relative,Non-condensing)
Operating Altitude	m	-200~3000
Non-Operating Altitude	m	-200~5000
vibration	--	10~500Hz,2G 10min./1cycle,period for 60min.each along X,Y,Z axes Compliance to IEC 68-2-6,IEC 68-2-64

Mechanical

Dimensions (WxHxD)	mm	170*48*248.8 / (6.69*1.88*9.8 inch)
Weight	KG	2.9KG/PC; 9PCS/Carton, 28.5KG
Cooling	--	conduction-cooling

Others

Warranty		1Years,
MTBF	h	250000,MIL-HDBK-217F@25 $^{\circ}C$

DE-Rating Curve

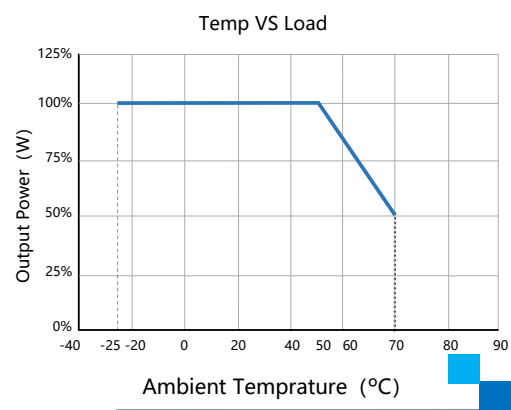
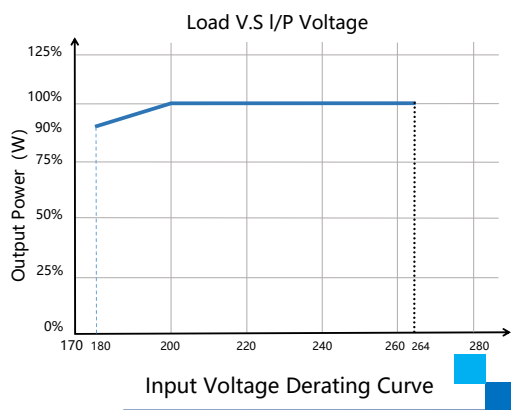

PIN Definition

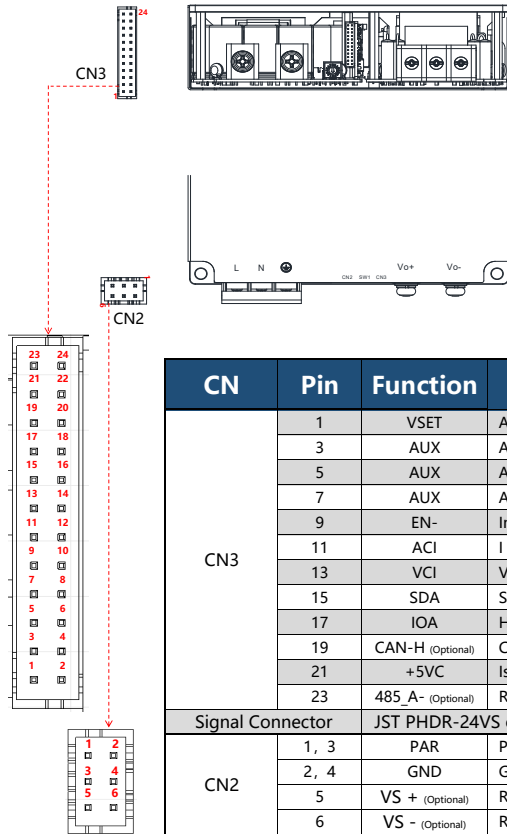

Pin	Function
L	AC Input L
N	AC Input N
⊕	AC Input FG
Vo+	DC Output (+)
Vo-	DC Output (-)
SW1	Addr

CN	Pin	Function	Description	Pin	Function	Description	
CN3	1	VSET	Aux output setting 5V/12V	2	POK	Power OK	
	3	AUX	Auxiliary output positive	4	GND	Ground	
	5	AUX	Auxiliary output positive	6	GND	Ground	
	7	AUX	Auxiliary output positive	8	EN+	Inhibit ON/OFF (+)	
	9	EN-	Inhibit ON/OFF (-)	10	GND	Ground	
	11	ACI	I Program	12	GND	Ground	
	13	VCI	V Program	14	GND	Ground	
	15	SDA	Serial Data Line	16	SCL	Serial Clock Line	
	17	IOA	High speed I/O port	18	IOB	Low speed I/O port	
	19	CAN-H (Optional)	Controller Area Network-H	20	CAN-L (Optional)	Controller Area Network-L	
	21	+5VC	Isolation 5V positive	22	GNDI	Isolation 5V Ground	
	23	485 A- (Optional)	RS485 A+	24	485 B+ (Optional)	RS485 B-	
	Signal Connector JST PHDR-24VS or equivalent; JST SPHD-002T-P0.5 or equivalent						
	CN2	1, 3	PAR	Parallel operation current share			
2, 4		GND	Ground				
5		VS + (Optional)	Remote sense(+)				
6		VS - (Optional)	Remote sense(-)				
Signal Connector CJT A2006H-2x3P or equivalent; JST SPHD-002T-P0.5 or equivalent							

Remote ON/OFF

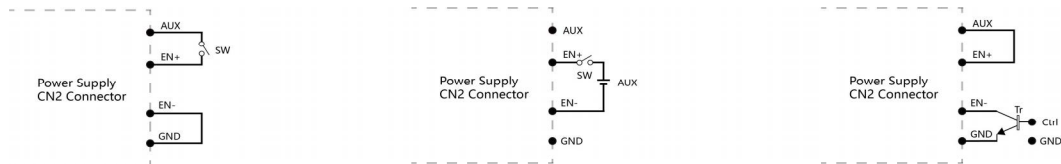

(a) Using internal 5V auxiliary source (Default Setting)

(b) Using external voltage source

(c) ON / OFF Control by NPN transistor

Note:
GND shown in above diagram is referring to the GND of CN2, not the Grounding from main power(V-).

Output Voltage/Current Programming

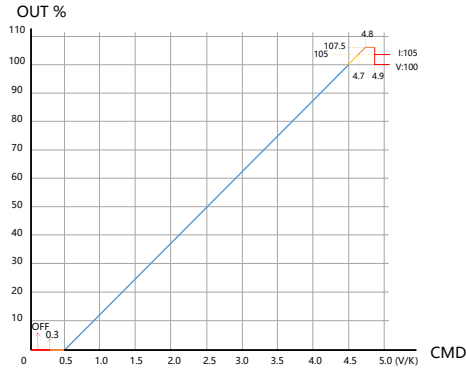

Optional edition
CMD VS Output Curve(0~5V)

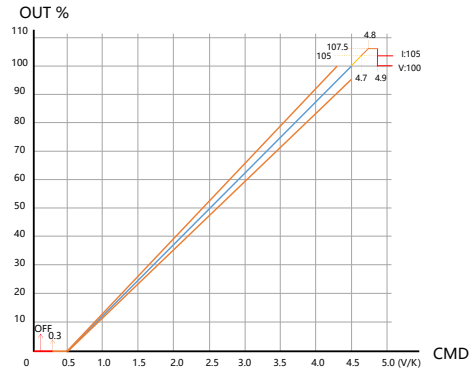

CMD VS Output Curve(0~5V)

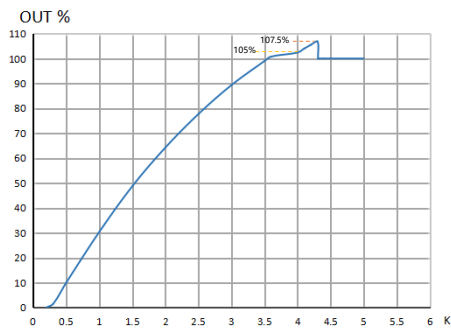

CMD VS Output Curve(0~5KΩ)

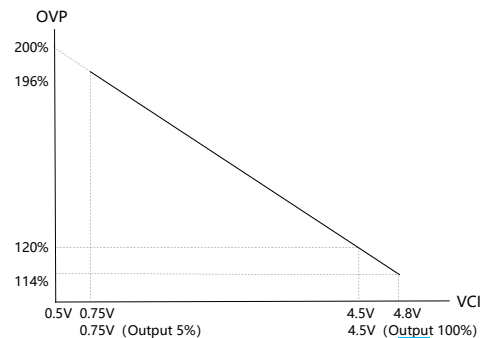

VCI VS OVP Curve

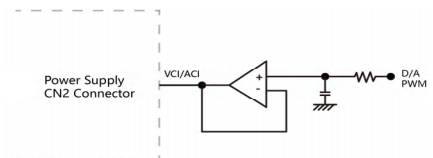
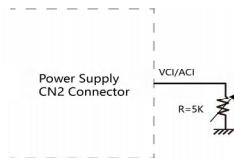
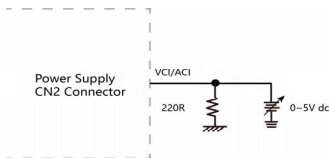

Power OK Signal & Auxiliary Power Setting

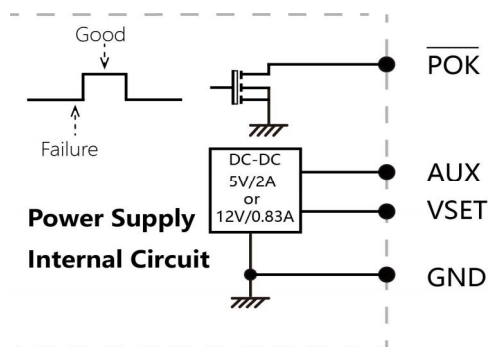

AUX and POK Signal

The grounding of "AUX" power and P.OK signals should be connected to "GND" port. If "V-" is connected as Grounding, make sure to short the GND and V- ports.

Do not exceed 5V/2A or 12V/0.83A

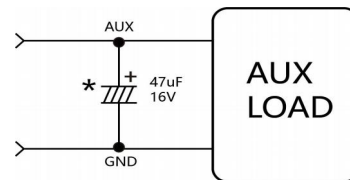

Auxiliary Power Setting

*Place an additional capacitor to have a better performance of auxiliary power operation.

Note:
GND shown in above diagram is referring to the GND of CN2, not the Grounding from main power(V-).

LED status indication

mode	Description	LED Signal	LED Slow=750ms; Fast=250ms
Local mode	Power Standby		Slow Blink (Green)
	Power OK		Solid (Green)
Remote mode	Power Standby		Slow Blink (Orange)
	Power OK		Solid (Orange)
Local/Remote mode	OTA		Alternating flicker (Red&Green)
	AC Input Over /Under Voltage Protection		Fast Blink (Red)
	BUS Over Voltage Protection (OVP)		Intermittent Blink (Red)
	Over Load Protection (OLP)		Interlace Blink (Red)
	Over Temperature Protection (OTP)		Slow Blink (Red)
	DC Output Over Voltage Protection (OVP)		Solid (Red)

Mechanical Drawings

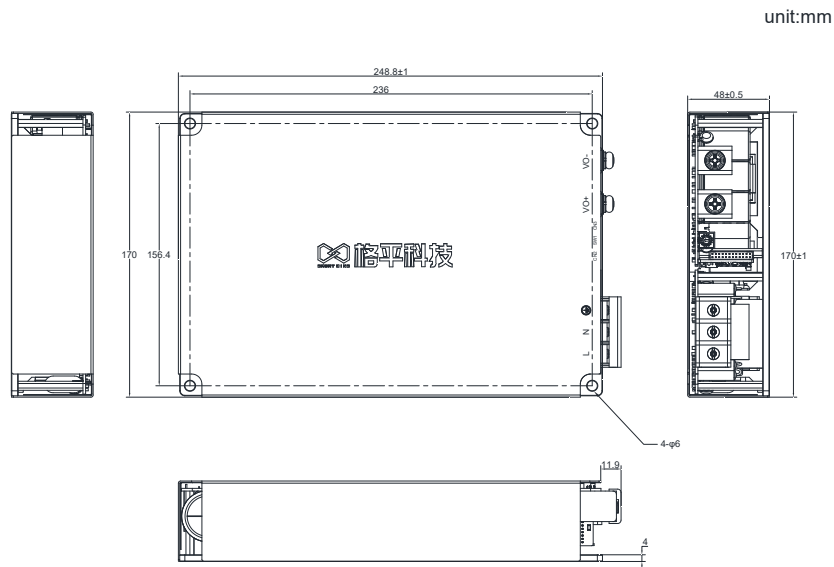

Notes:

- 1, Input: terminal block type. M4 screw torque value of 16kgf-cm using wire gauge 18-10 (13mm centers)
- 2, Output terminal block, M6 screw in 2 positions, torque3.5N m (35kgf cm)
- 3, Installation: The Maximum penetration of screw is 4mm.